

Scirocco^{plus}

DIMENSIONS AND TECHNICAL SHEETS
DIMENSIONS ET FICHES TECHNIQUES
DIMENSIONI E DATI TECNICI

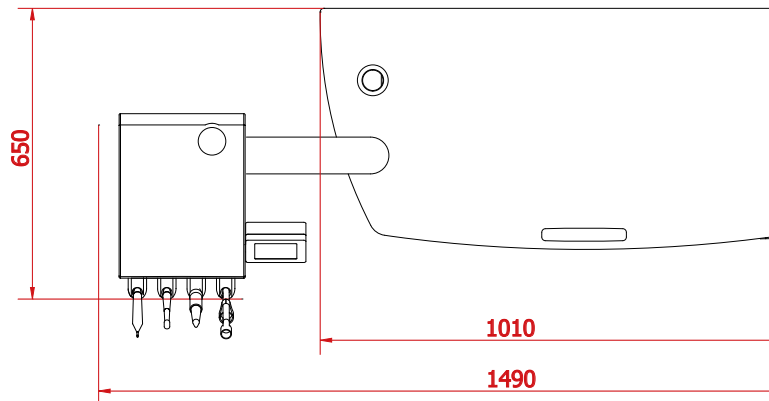
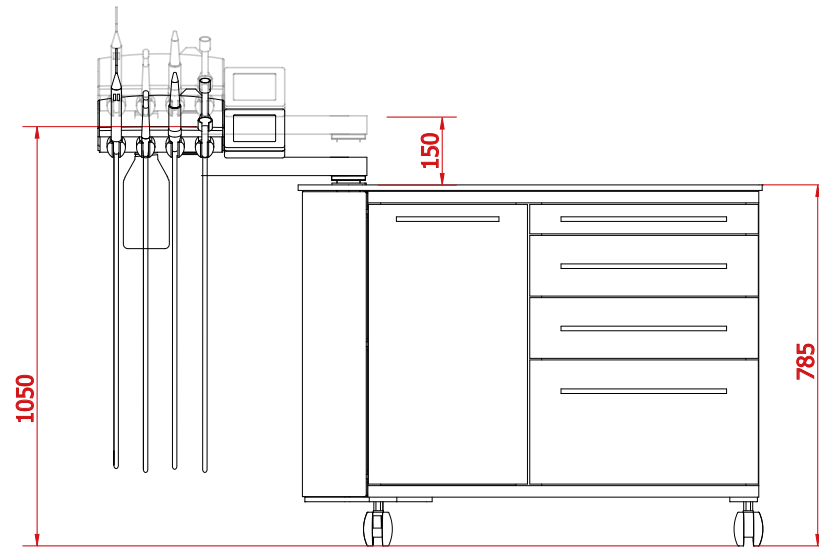

Innovative Medical Solutions

BTC Srl

Via Colombarotto, 34 40026 Imola (BO) Italy

Tel: +39 0542 643664

www.btc-med.it btcmed@btc-med.it

Supply Alimentazione	110- 230 V 50- 60 Hz
Absorption Assorbimento Podiatry unit Riunito Suction Aspirazione Lamp Lampada	80 W Max 1200 W Max 100 W
Air line inlet Ingresso aria In feed pressure Pressione Flow-rate Portata	5.0- 7.0 bar 10 l/min 45 l/min (with turbine set)
Noisiness Rumorosità	55 dB
Spray liquid tank capacity Capacità della tanica	0,5 l
Unit weight Peso dell'unità	98 Kg