

Workstations



Innovative Medical Solutions

WHO WE ARE | QUI NOUS SOMMES | CHI SIAMO

THE COMPANY

BTC Medical Equipment is specialized in developing and manufacturing Multispecialty Examination and Procedure Chairs, Podiatry Units and Chairs, Gait Analysis and Orthotics Equipment.

BTC is committed to the continuous research of innovative technical solutions for the Professionals; the range of equipment offered is based on and follows rigid guidelines: latest technology, perfect work-flow ergonomics, reliability, design and highly intuitive and easy to operate by the Professional.

The Company is directly involved through all development, manufacturing, assembly and quality control, shipment, installation and after-sale service phases thanks to its vast network of Distributors and Agents.

In the Company premises located in IMOLA BTC has set up a permanent Show-Room, a Training Area for theory-practice sessions and the interna Service Department.

A well structured company organization that has enabled BTC to grow at national and international level keeping the highest quality standards and constant innovation of its range of products.

ENTREPRISE

BTC Medical Equipment est spécialisée dans la conception et la fabrication de Fauteuils Polivalents et pour la Chirurgie Ambulatoire, d'équipements pour l'analyse posturale et la fabrications d'orthesis, ainsi que de Fauteuils et Unités de soin pour la Podologie.

BTC est engagée dans la recherche constante de solutions innovantes pour les opérateurs professionnels; la gamme qu'elle propose suit des directives très précises: ergonomie, fiabilité, design et une simple utilisation pour les opérateurs.

BTC est directement impliquée dans chaque phases de conception et de développement de ses produits, à partir de la production et l'assemblage, au contrôle, jusqu'à l'expédition et la distribution, offrant un support technique et commercial complet et compétent. Tout cela grâce à un réseau coordonné et capillaire reliant ses agents et ses partenaires-distributeurs et grâce à son service après-vente interne.

A l'intérieur de son établissement à Imola, BTC propose une salle d'exposition permanente, une salle de formation pour l'entraînement théorique et pratique ainsi que son département de service technique et après-vente.

Une organisation qui nous a permis de nous développer au bout des années sur le marché Nationale et Internationale, toujours en gardant les plus hauts standards de qualité et un renouvellement constant de notre gamme de produits.



“All BTC Medical Equipment is designed, developed and manufactured in Italy”

L'AZIENDA

BTC Medical Equipment è specializzata nella progettazione e nella fabbricazione di Poltrone Multispecialistiche e Day Surgery, Poltrone e Riuniti da Podologia, Attrezzature per l'analisi posturale e la realizzazione di plantari.

BTC è impegnata nella continua ricerca di soluzioni innovative per gli Operatori professionali; la gamma che propone si basa su linee guida molto rigide: ergonomia, affidabilità, design e massima semplicità di utilizzo per gli Operatori.

L'Azienda è direttamente coinvolta in tutte le fasi di progettazione e sviluppo, produzione e assemblaggio, controllo, spedizione e commercializzazione, offrendo un supporto tecnico e commerciale completo e competente grazie ad una rete capillare di Agenti e Distributori ed un Servizio Assistenza Interno.

Nella sede principale di Imola BTC offre uno Show-room permanente, una Sala Corsi per la Formazione teorico-pratica ed il servizio di Assistenza Tecnica.

Una organizzazione aziendale che ci ha permesso in pochi anni di crescere a livello nazionale ed internazionale mantenendo i più alti standard qualitativi e il rinnovamento costante della gamma prodotti.



HOW WE WORK | COMMENT NOUS TRAVAILLONS | COME LAVORIAMO

R&D

BTC R&D Team develops internally all the equipment and devices for the Professionals and Clinics, always combining modern and essential design to the latest and most innovative technical solutions.

L'équipe BTC Design développe en interne tout équipements dédiés au Professionnel et à la Cabinet, toujours en alliant un design moderne avec les solutions techniques les plus fonctionnelles et innovantes.

Il Team di Progettisti BTC sviluppa internamente tutte le attrezzature dedicate al Professionista e alla Clinica, coniugando sempre con attenzione un design moderno alle soluzioni tecniche e funzionali più innovative.



R&D
R&D
R&D



BTC manufactures a wide and complete range of Units, Chairs and Doctor Stools in its premises located in Imola. Every single production phase is planned and performed according to the most rigid quality control criteria that have enabled BTC to obtain the ISO:13485 Quality Certificate by CISQ/IMQ

BTC réalise sa gamme complète au sein de son établissement de Imola. Fauteuils, Sièges praticien et Unités de soin, chaque phase de la production est organisée suivant des critères très stricts de qualité et de contrôle demandés par la Certification Qualité ISO: 13485

BTC produce una gamma completa di Riuniti, Poltrone e Sgabelli all'interno degli stabilimenti siti in Imola. Ogni fase produttiva è organizzata secondo rigidi criteri di qualità e controllo grazie ai quali BTC ha ottenuto la certificazione di qualità ISO:13485



PRODUCTION
PRODUCTION
REALIZZAZIONE



BTC will design your Ambulatory in order to allow for the best work-flow and ergonomics while guaranteeing maximum comfort to the Patient, according to the space availability and your different set up needs as a Professional.

Nous étudions les meilleures solutions de projet pour votre Cabinet, afin de vous garantir une parfaite ergonomie et un maximum de confort, tout en gardant toujours les solutions les plus adaptées à votre espace.

Progettiamo il tuo Ambulatorio per garantirti la migliore ergonomia di lavoro e il massimo comfort proponendo sempre le soluzioni più adeguate al tuo spazio.

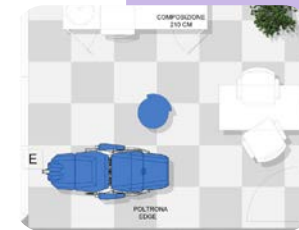

PROJECT
PROJET
PROGETTO

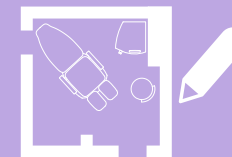

INSTALL
INSTALL
INSTALL



All BTC equipment is "Plug-in & Work" easy to set up and ready to use with very few and easy installation steps. BTC guarantees a highly professional installation service thanks to its vast network of Distributors and Agents, and a product specialist will train the Ambulatory staff on the correct use of the installed equipment.

Tous les équipements BTC sont fabriqués suivant le principe du "Plug-in & Work", facile à installer et avec un service d'expédition et de livraison consolidés. BTC garantit un service professionnel d'installation de votre Cabinet grâce à un réseau de distributeurs impliqués dans chaque phase. Un de nos technico-commerciaux vous garantira une formation complète pour l'utilisation de tout équipements à l'intérieur de votre Cabinet.

Tutte le Attrezzature BTC sono realizzate con il principio del "Plug-in & Work", facili da installare e con un servizio di spedizione e consegna dedicato.

BTC garantisce un servizio professionale di allestimento del tuo Ambulatorio grazie ad una vasta rete di Distributori che ne seguono ogni fase. Un nostro product specialist garantirà la formazione in loco sull'utilizzo delle attrezzature installate nel tuo Ambulatorio.



BTC is committed to continuous training and information of all its Customers; the Company can rely on the cooperation with prominent experts in each medical discipline and often involved in training sessions on the specific equipment and different operating methods.

BTC connaît l'importance de promouvoir de l'information et de la formation de tous ses clients, en collaboration avec des experts du secteur et en organisant des sessions de formations dédiées aux équipements et à techniques très spécifiques.

BTC promuove da sempre l'informazione e la formazione dei suoi clienti collaborando con prominenti esperti di settore e organizzando sessioni e corsi di formazione dedicati alle varie e specifiche attrezzature e metodiche operative.



BTC considers Warranty a professional duty and mandatory towards all its Customers, reason being the Company extends guarantee of the equipment up to 2 Years on Electronic Parts and up to 5 Years on Mechanic Parts.

BTC considère la garantie des produits comme un engagement ferme envers tous ses clients. Pour cette raison, la garantie de nos équipements couvre jusqu'à 2 ans pour les composants électroniques et jusqu'à 5 ans tout composants mécaniques.

BTC considera la Garanzia dei prodotti un dovere verso tutti i suoi clienti e per questo garantiamo le nostre attrezzature fino a 2 anni per le componenti elettroniche e fino a 5 anni per tutte le componenti meccaniche.

All Customers can rely on a punctual and qualified after-sale assistance thanks to the in-house Service Department. You will be able to request a Preventive Maintenance and Courtesy Service to our Distributors and avoid any unexpected interruption of your professional activity.

Nos clients peuvent compter sur un SAV rapide et qualifié, grâce à son Département interne. Vous aurez également la possibilité de profiter d'un service de maintenance programmé, ainsi que d'un "Service de Courtoisie" assuré par nos Distributeurs afin d'éviter toute interruption de votre activité professionnelle.

I nostri clienti possono contare su un Servizio di Assistenza puntuale e qualificato grazie al dipartimento Service interno. Avrai la possibilità di richiedere un Servizio di Assistenza Programmata e il Servizio "Cortesia" al Distributore incaricato per non avere mai interruzioni della tua attività professionale.



INSTALLATION
INSTALLAZIONE



TRAINING
FORMATION
FORMAZIONE



WARRANTY
GARANTIE
GARANZIA



SERVICE
SERVICE APRES-VENTE
ASSISTENZA





Cabinet 50 cm width. Standard configuration with 4 drawers with metal fronts without handles and Push-Pull opening system. Equipped with internal instrument trays. Mobile on wheels for a comfortable handling (the two front wheels are equipped with brakes). Corian worktop. Suitable for a lamp support and a tray holder (Ø 12.5 and Ø 16 mm).

Meuble de rangement avec largeur 50 cm. Configuration standard avec 4 tiroirs à façades métalliques sans poignées et système d'ouverture Push-Pull. Équipé de plateaux d'instruments internes. Meuble sur roues (les deux roues avant sont équipées de freins). Plan de travail en Corian. Prédéposé pour un support de l'éclairage et un support pour le plateau des instruments (Ø 12,5 et Ø 16 mm).

Mobile con larghezza 50 cm. Configurazione standard con 4 cassetti con frontali in metallo senza maniglie e sistema di apertura Push- Pull. All'interno dei cassetti, vassoi porta strumenti. Mobile su ruote (le due anteriori con freno) per la movimentazione. Piano in Corian. Possibilità di supporto lampada e supporto porta- tray (Ø 12,5 e Ø 16 mm).

codice	descrizione
9210856	COLIBRÌ WORKSTATION



**OPTIONAL ACCESSORIES
MORE INFO ON PAGE 12-14**



plug & work



working top



disinfection



Cabinet 50 cm width. Standard configuration with 4 drawers with metal fronts without handles and Push-Pull opening system. Equipped with internal instrument trays. Corian side compartment for the equipment lodging (load capacity 8 kg). Mobile on wheels for a comfortable handling (the two front wheels are equipped with brakes). Corian worktop. Suitable for a lamp support and a tray holder (Ø 12.5 and Ø 16 mm).

Meuble de rangement avec largeur 50 cm. Configuration standard avec 4 tiroirs à façades métalliques sans poignées et système d'ouverture Push-Pull. Équipé de plateaux d'instruments internes. Compartiment latéral en Corian pour accueillir l'instrumentation (capacité de charge 8 kg). Meuble sur roues (les deux roues avant sont équipées de freins). Plan de travail en Corian. Prédéposé pour un support de l'éclairage et un support pour le plateau des instruments (Ø 12,5 et Ø 16 mm).

Mobile con larghezza 50 cm. Configurazione standard con 4 cassetti con frontali in metallo senza maniglie e sistema di apertura Push- Pull. All'interno dei cassetti, vassoi porta strumenti. Vano laterale sottopiano per strumentazione (capacità di carico 8 kg). Mobile su ruote (le due anteriori con freno) per la movimentazione. Piano in Corian. Possibilità di supporto lampada e supporto porta- tray (Ø 12,5 e Ø 16 mm).

codice	descrizione
9210868	COLIBRÌ M WORKSTATION



OPTIONAL ACCESSORIES
MORE INFO ON PAGE 12-14



plug & work



working top



disinfection



Cabinet 90 cm width with 6 drawers (2 drawers 40 cm wide and 6 drawers 50 cm wide) with metal fronts without handles and Push-Pull opening system. Extendable metal shelf with Soft Touch system (also available with fixed shelf). Equipped with internal instrument trays. Mobile on wheels for a comfortable handling (the two front wheels are equipped with brakes). Corian worktop. Suitable for a lamp support and a tray holder (Ø 12.5 and Ø 16 mm).

Meuble de rangement avec largeur 90 cm avec 6 tiroirs (2 tiroirs largeur 40 cm et 6 tiroirs largeur 50 cm) à façades métalliques sans poignées et système d'ouverture Push-Pull. Étagère métallique extensible avec système Soft Touch (également disponible avec étagère fixe). Équipé de plateaux d'instruments internes. Meuble sur roues (les deux roues avant sont équipées de freins). Plan de travail en Corian. Prédéposé pour un support de l'éclairage et un support pour le plateau des instruments (Ø 12,5 et Ø 16 mm).

Mobile con larghezza 90 cm a 6 cassetti (2 cassetti largh. 40 cm e 6 cassetti largh. 50 cm) con frontali in metallo senza maniglie e sistema di apertura Push- Pull. Piano estraibile in lamiera con guida Soft Touch (disponibile anche con ripiano fisso). All'interno dei cassetti, vassoi porta strumenti. Mobile su ruote (le due anteriori con freno) per la movimentazione. Piano in Corian. Possibilità di supporto lampada e supporto porta- tray (Ø 12,5 e Ø 16 mm).

codice	descrizione
9210871	SCIROCCO 90 WORKSTATION (extendable shelf)
9210871-F	SCIROCCO 90 WORKSTATION (fixed shelf)



**OPTIONAL ACCESSORIES
MORE INFO ON PAGE 12-14**



plug & work



working top



disinfection





Cabinet 85 cm width with 8 drawers (2 M1, 4 M2 e 2 M4) with metal fronts without handles and Push-Pull opening system. Equipped with internal instrument trays. Mobile on wheels for a comfortable handling (the two front wheels are equipped with brakes). Corian worktop. Suitable for a lamp support and a tray holder (Ø 12.5 and Ø 16 mm).

Meuble de rangement avec largeur 85 cm avec 8 tiroirs (2 M1, 4 M2 e 2 M4) à façades métalliques sans poignées et système d'ouverture Push-Pull. Équipé de plateaux d'instruments internes. Meuble sur roues (les deux roues avant sont équipées de freins). Plan de travail en Corian. Prédéposé pour un support de l'éclairage et un support pour le plateau des instruments (Ø 12,5 et Ø 16 mm).

Mobile con larghezza 85 cm. Configurazione standard con 8 cassetti (2 M1, 4 M2 e 2 M4) con frontali in metallo senza maniglie e sistema di apertura Push- Pull. All'interno dei cassetti, vassoi porta strumenti. Mobile su ruote (le due anteriori con freno) per la movimentazione. Piano in Corian. Possibilità di supporto lampada e supporto porta- tray (Ø 12,5 e Ø 16 mm).

codice	descrizione
--------	-------------

9210866	SCIROCCO 85 WORKSTATION
---------	----------------------------



OPTIONAL ACCESSORIES
MORE INFO ON PAGE 12-14



plug & work



working top



disinfection



Corian® worktop.
Corian® meets the stringent design requirements for medical environments. Easy to clean and maintain. LGA certified for its hygienic properties (stability against bacteria). Smooth, nonporous and no welding surface, extremely durable overtime and impact resistant.

Plan de travail en Corian®.
Corian® répond aux strictes exigences de conception liées aux environnements médicaux. Facile à nettoyer et entretenir. Certifié LGA pour ses propriétés hygiéniques (stabilité contre les bactéries). Surface lisse, non poreuse et sans soudures. Extrêmement durable, résistant aux chocs.

Piano in Corian®.
Corian® soddisfa i severi requisiti del design per gli ambienti sanitari. Facile da pulire e di semplice manutenzione. Dotato di certificazione LGA per le proprietà igieniche (stabilità contro batteri e funghi). Superficie non porosa con un look fluido e senza giunture. Estremamente resistente e di lunga durata, resistente ai colpi più duri negli ambienti ad alta frequentazione.



Workstation is manufactured with a steel structure painted with epoxy powders, able to ensure the maximum resistance over time.

Workstation est fabriqué avec une structure en acier peint avec poudres époxy afin d'assurer le maximum de résistance dans le temps.

Workstation è costruito con una struttura in acciaio verniciato con polveri epossidiche per garantire una grande resistenza nel tempo.



Workstation is equipped with powder coated steel front drawers with Push Pull opening system. The absence of handles provides easy cleaning and disinfection. The front drawers can be customized with a color at choice among the wide range of RAL colors available.

The front drawers are equipped with Push-Pull guiding rails with a stabilizer bar. Opening by a simple pressing on any spot of the front drawer.

Workstation est équipé de façades en acier thermolaqué avec ouverture Push Pull. L'absence de poignées permet une grande facilité de nettoyage et désinfection. Les façades peuvent être personnalisées avec une couleur à choix parmi la gamme de couleurs RAL disponibles. Les tiroirs sont montés avec des guides Push-Pull équipés d'une barre stabilisatrice. L'ouverture est simple en appuyant sur n'importe quel coin de la façade.

Workstation è dotato di frontali in acciaio verniciato a polvere con apertura Push Pull. L'assenza di maniglie permette una grande facilità di pulizia. I frontali sono personalizzabili con colore a scelta all'interno di un'ampia gamma di colori RAL disponibili.

I cassetti montati su guide Push Pull dotate di barra stabilizzatrice sono facilmente apribili, semplicemente premendo in qualsiasi punto del frontale.



Workstation is equipped with 8 medical grade wheels, 4 at the front are equipped with locking brakes. The swivel wheel is equipped with a polyamide support, as well as the central section of the wheel. The side band is made of thermoplastic polyurethane. Diameter 75 mm.

Workstation est équipé de 8 roues de qualité médicale, 4 à l'avant équipées avec freins de blocage et 4 à l'arrière. La roue pivotante est équipée d'un support en polyamide, ainsi que la section centrale de la roue. La bande est en polyuréthane thermoplastique. Diamètre 75 mm.

Workstation è dotato di 8 ruote medicali, 4 anteriori con freno bloccabile e 4 posteriori. La ruota girevole è dotata di un supporto in poliammide, così come il centro della ruota. La fascia è in poliuretano termoplastico. Diametro della ruota 75 mm.



codice	descrizione
9210803	TAVOLETTA PORTA TRAY



Instruments tray support.
OPTIONAL

Support pour plateau des instruments.
EN OPTION

Supporto per vassoio porta strumenti.
OPZIONALE

codice	descrizione
9210872	LED UV PER CASSETTO SU W/S

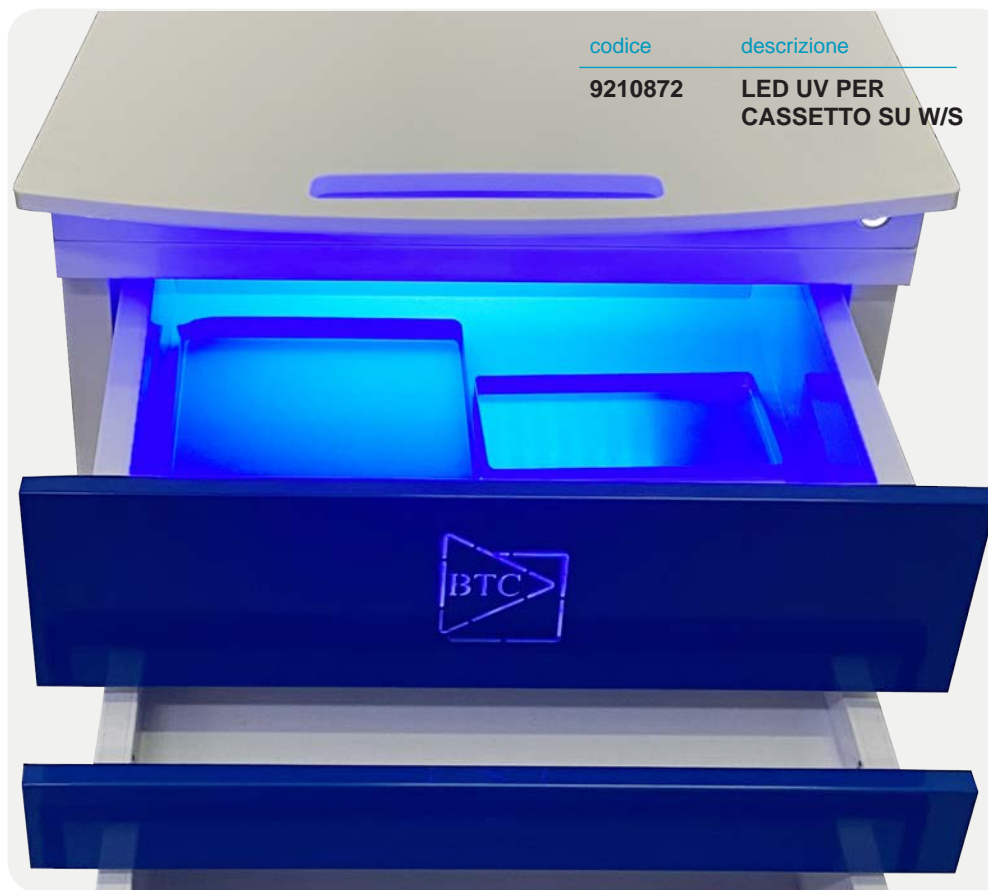

UV M2 drawer with power switch. Internal trays in aluminum.
OPTIONAL

Tiroir UV M2 avec interrupteur. Plateaux internes en aluminium.
EN OPTION

Cassetto M2 con luce led UV con tasto di accensione luminoso. Vassoi interni in alluminio.
OPZIONALE



UV light

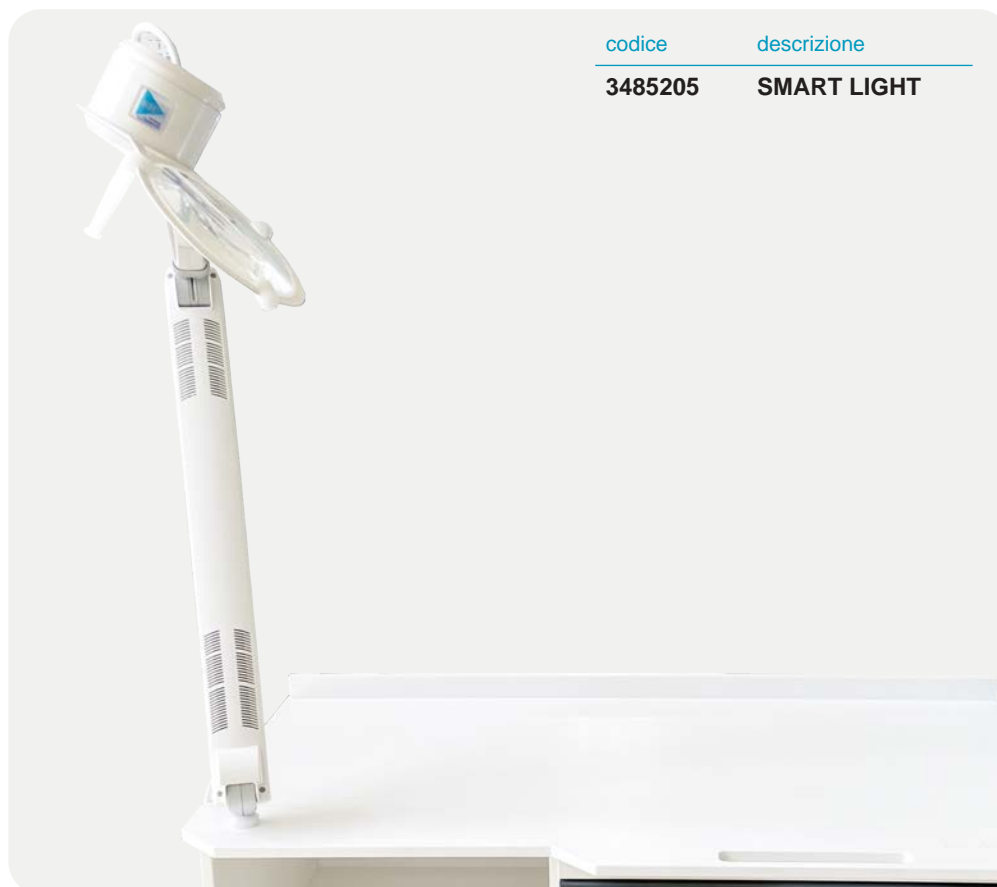

codice	descrizione
3485205	SMART LIGHT

Sterilizable handle. 40,000 working hours. Supply (16W). Cold light.

OPTIONAL

Poignée stérilisable. 40 000 heures de travail. Alimentation (16W). Lumière froide.

EN OPTION

Impugnatura sterilizzabile 40.000 ore di lavoro Potenza (16W). Luce fredda.

OPZIONALE



codice	descrizione
9110640	LED LAMP

LED Examination Lamp, 50.000LUX at 50cm distance, 4.400°K, CRI 93.

OPTIONAL

Eclairage d'examen LED 50.000LUX en distance de 50cm 4.400°K de température couleur et CRI 93.

EN OPTION

Lampada da Visita LED, 50.000LUX a 50cm di distanza, 4.400°K di temperatura colore e CRI 93.

OPZIONALE

Max. light power <i>Puissance maximale d'éclairage</i> Potenza illuminazione massima	50.000 lux @ 50 cm
Light adjustment <i>Réglage luminosité</i> Regolazione luminosità	5 dimming levels
Light field diameter (d50) <i>Diamètre du champ éclairé (d50)</i> Diametro del campo illuminato (d50)	18 cm @ 50 cm
Colour temperature <i>Température de couleur</i> Temperatura di colore	4.400 °K (fixed) Adjustable: 3.300 K, 3.800 K, 4.4000 K
Colour rendering index (Ra) <i>Index de rendu de couleur (Ra)</i> Indice di resa di colore (Ra)	93



codice	descrizione
9110655	LED LAMP

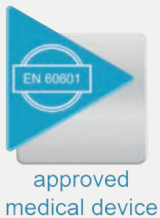

LED Examination Lamp, 100.000LUX at 50cm distance, 5.500°K, CRI 98.
Through touch control panel it is possible to manage all the functions of the lamp.

OPTIONAL

Eclairage d'examen LED 100.000LUX en distance de 50cm 5.500°K de temperature couleur et CRI 98.
Grâce au panneau de commande tactile on peut gérer toutes les fonctions de la lampe.

EN OPTION

Lampada da Visita LED, 100.000LUX a 50cm di distanza, 5.500°K di temperatura colore e CRI 98.
Tramite il pannello comandi a sfioramento è possibile gestire tutte le funzioni della lampada

OPZIONALE



Product Class EN 60601-2-41 Classe EN 60601-2-41 Classificazione EN 60601-2-41	II
Max. light power Puissance maximale d'éclairage Potenza illuminazione massima	100.000 lux @ 50 cm 30.000 lux @ 100 cm
Light adjustment Réglage luminosité Regolazione luminosità	da 20% à 100%
Light field diameter (d10) Diamètre du champ éclairé (d10) Diametro del campo illuminato (d10)	26 cm
Colour temperature Température de couleur Temperatura di colore	3.000- 5.500 °K
Colour rendering index (Ra) Index de rendu de couleur (Ra) Indice di resa di colore (Ra)	90-98
LED average life Durée moyenne LED Durata media LED	60.000 hours
Voltage Tension de réseau Tensione di rete	100-240VAC 50/60 Hz
Power consumption Consumation d'énergie Potenza assorbita	12VA

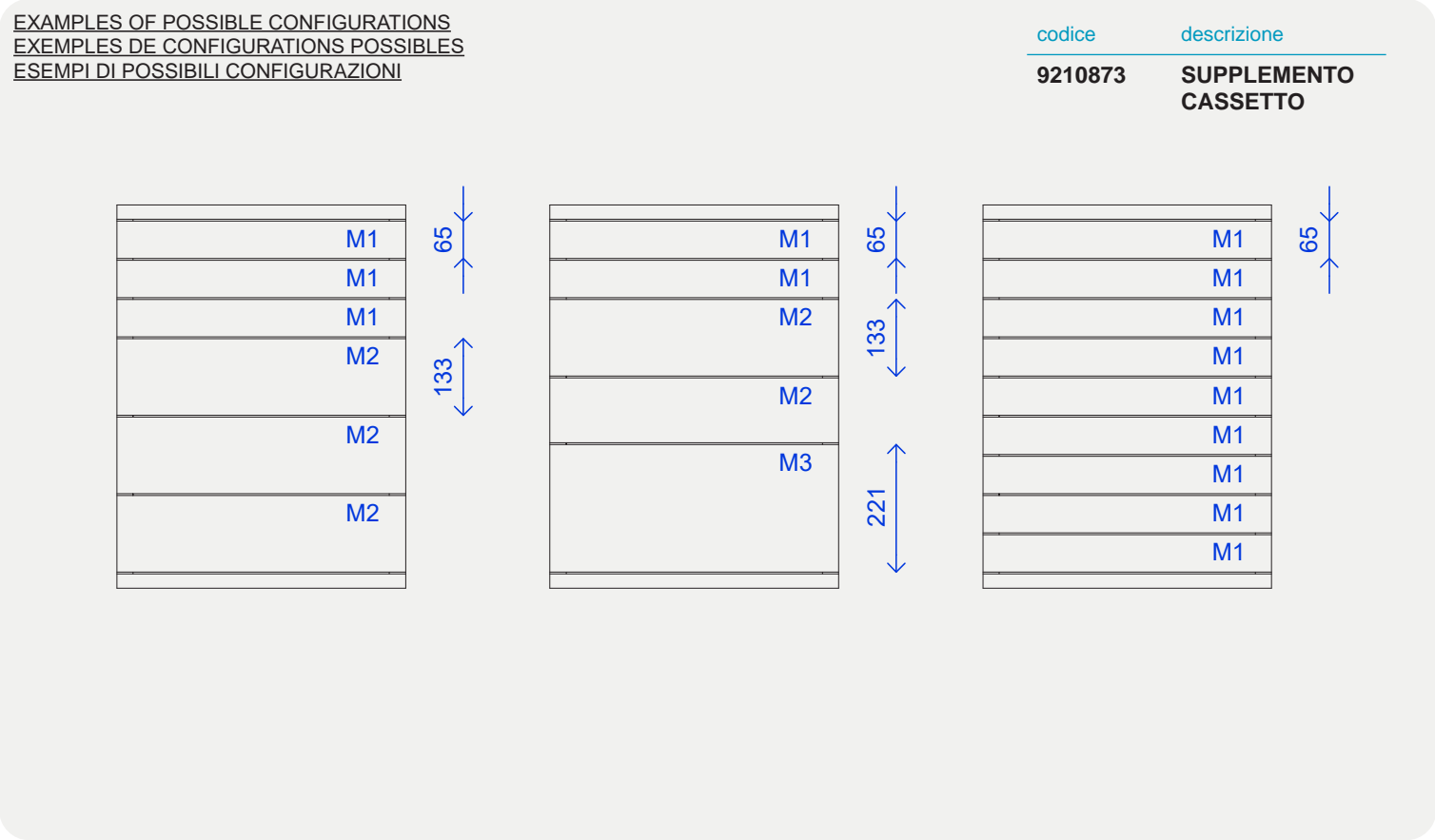
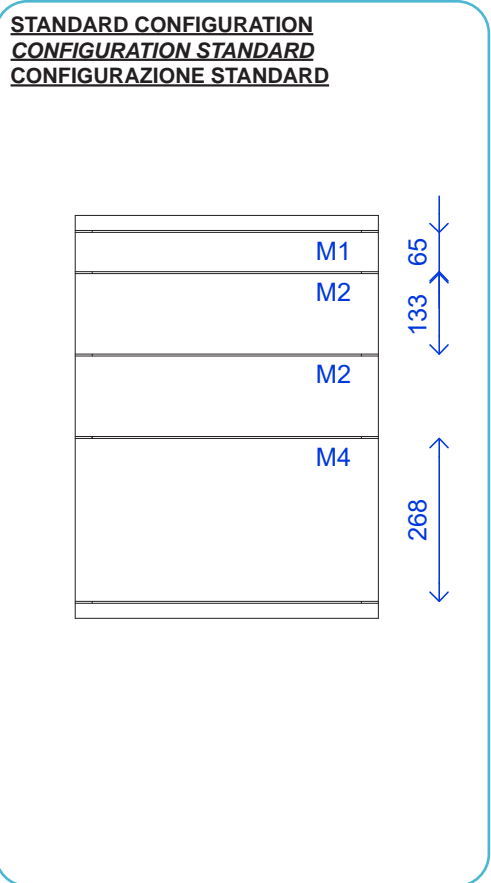

The standard configuration includes 4 drawers: 1 M1, 2 M2 and 1 M4.
 A surcharge is to be considered for any additional drawers (starting from the fifth drawer).
 The number of drawers can not exceed a total of M9.
 Drawer height: M1 = 6.5 cm | M2 = 13.3 cm | M3 = 22.1 cm | M4 = 26.8cm

*La configuration standard comprend 4 tiroirs : 1 M1, 2 M2 et 1 M4.
 Un supplément est à prévoir pour l'ajout de tiroirs (à partir du cinquième tiroir).
 Le nombre de tiroirs ne peut pas dépasser un total de M9.
 Hauteur du tiroir : M1 = 6,5 cm | M2 = 13,3 cm | M3 = 22,1 cm | M4 = 26,8 cm*

La configurazione standard della cassetiera è 4 cassetti: 1 M1 , 2 M2 e 1 M4.
 È previsto un supplemento per l'aggiunta di cassetti (dal quinto cassetto in poi).
 Il numero di cassetti non può superare un totale di M9.
 Altezza cassetti: M1= 6,5 cm | M2= 13,3 cm | M3= 22,1 cm | M4= 26,8 cm

DIMENSIONS AND TECHNICAL SHEETS
DIMENSIONS ET FICHES TECHNIQUES
DIMENSIONI E DATI TECNICI

Colibrì Workstation

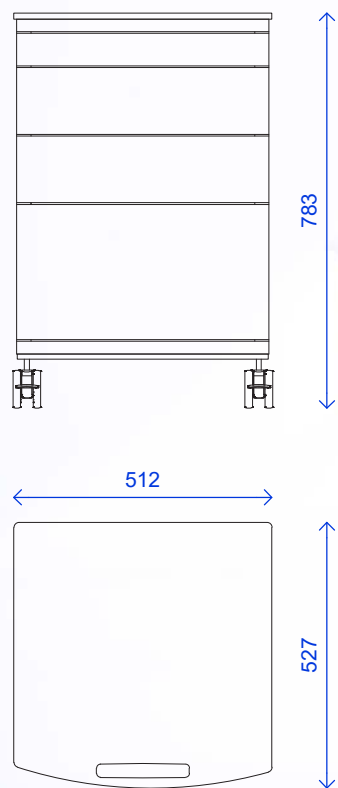

Colibrì M Workstation

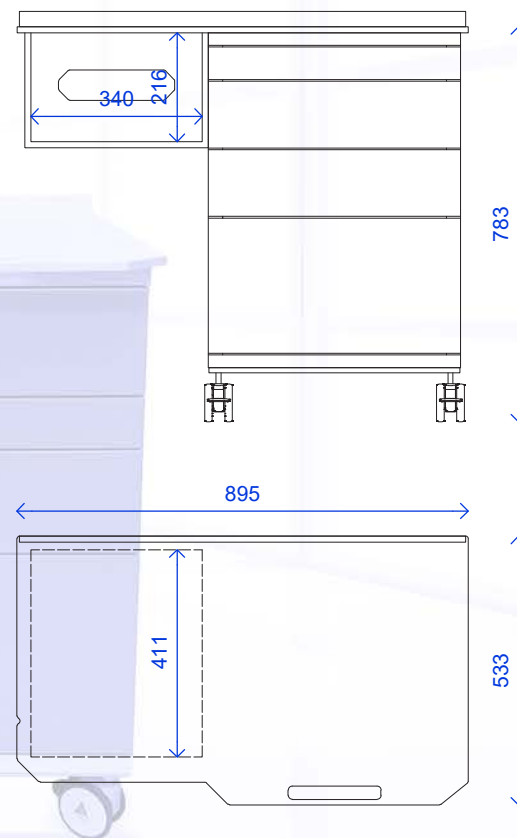

DIMENSIONS AND TECHNICAL SHEETS
DIMENSIONS ET FICHES TECHNIQUES
DIMENSIONI E DATI TECNICI

Scirocco 85 Workstation

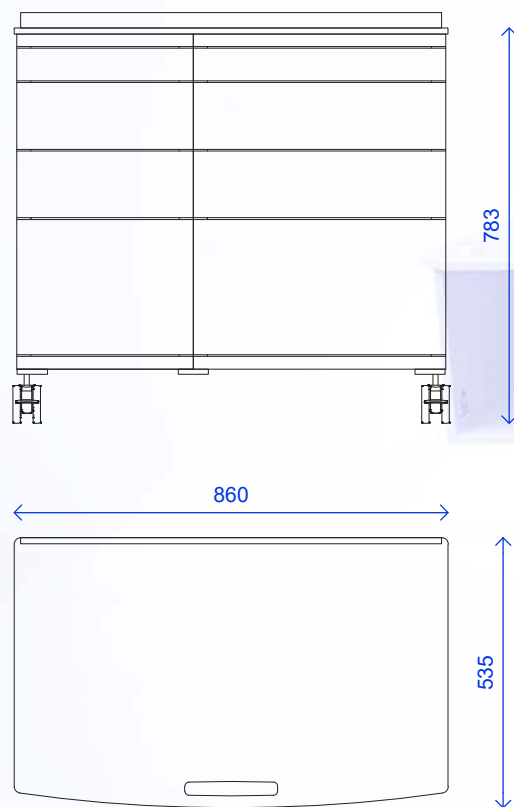

Scirocco 90 Workstation

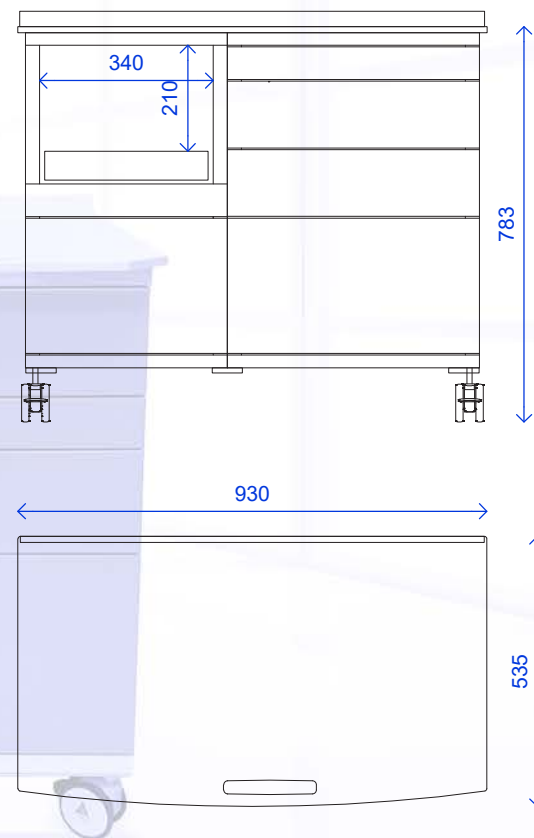

COLOURS
COULEURS
COLORI

RAL 9023 (1.06)	RAL 1035 (1.07)	RAL 9023 (1.08)	RAL 8029 (1.09)	RAL 9007 (1.10)	RAL 5026 (1.11)	RAL 7042 (2.05)	RAL 7015 (2.06)	RAL 4002 (2.07)	RAL 5013 (2.08)
RAL 1001 (2.09)	RAL 8028 (2.10)	PANTONE 389C (4.01)	RAL 5005 (4.02)	RAL 4010 (4.03)	RAL 6034 (4.05)	RAL 3017 (4.06)	RAL 7036 (4.07)	PANTONE 391C (5.04)	RAL 8023 (5.05)
RAL 3031 (5.06)	RAL 1002 (5.07)	RAL 5023 (5.08)	RAL 7024 (5.09)	RAL 7021 (6.07)	RAL 5008 (6.08)	RAL 5009 (6.09)	RAL 7037 (6.10)	RAL 7036 (6.11)	RAL 8019 (6.12)
RAL 5000 (6.13)	RAL 5007 (6.14)	RAL 6027 (6.15)	RAL 5025 (6.16)	RAL 6000 (6.17)	RAL 3005 (6.18)	RAL 3027 (6.19)	RAL 3022 (6.20)	RAL 1032 (6.21)	RAL 1019 (6.22)
RAL 8017 (7.07)	RAL 7006 (7.08)	RAL 7044 (7.09)	RAL 3005 (7.10)	RAL 6003 (7.11)	RAL 5009 (7.12)	RAL 5022 (8.30)	RAL 3003 (8.31)	RAL 7040 (8.32)	RAL 9010 (8.33)
RAL 7036 (8.34)	RAL 8025 (8.35)	RAL 8017 (8.36)	RAL 5009 (8.37)	RAL 6034 (8.38)	PANTONE 391C (8.39)	RAL 1023 (8.40)	RAL 4010 (8.41)	RAL 8019 (9.03)	RAL 2003 (9.04)
RAL 3020 (9.05)	RAL 3005 (9.06)	RAL 8004 (9.07)	RAL 9006 (9.08)	RAL 5007 (9.09)	RAL 5013 (9.10)	RAL 7035 (9.11)	RAL 5023 (9.12)	RAL 5024 (9.13)	RAL 6027 (9.14)
RAL 7021 (9.15)	RAL 7039 (9.16)	RAL 7037 (9.17)	RAL 1013 (9.18)	RAL 1015 (9.19)	RAL 8024 (9.20)	RAL 8016 (9.21)	RAL 1036 (9.22)	RAL 4005 (9.23)	RAL 7021 (10.01)

A series of horizontal dotted lines for writing notes.



www.btc-med.it



btcmmed@btc-med.it



[btcmmedicalequipment](https://www.facebook.com/btcmmedicalequipment)



[btcmmedicalequipment](https://www.instagram.com/btcmmedicalequipment)



10059847



0152.2020



*“All BTC Medical Equipment is designed,
developed and manufactured in Italy”*

BTC Srl

via Altobelli Bonetti, 8/A

40026 Imola (BO)

Tel. +39 0542 643664

Fax. +39 0542 647391